

LOC	DIST	P	F	ZONE	LTR	DESCRIPTION	DATE	APPD
AF	50				E	REV PER 0G1A-0048-99	04JUN99	JR/DD

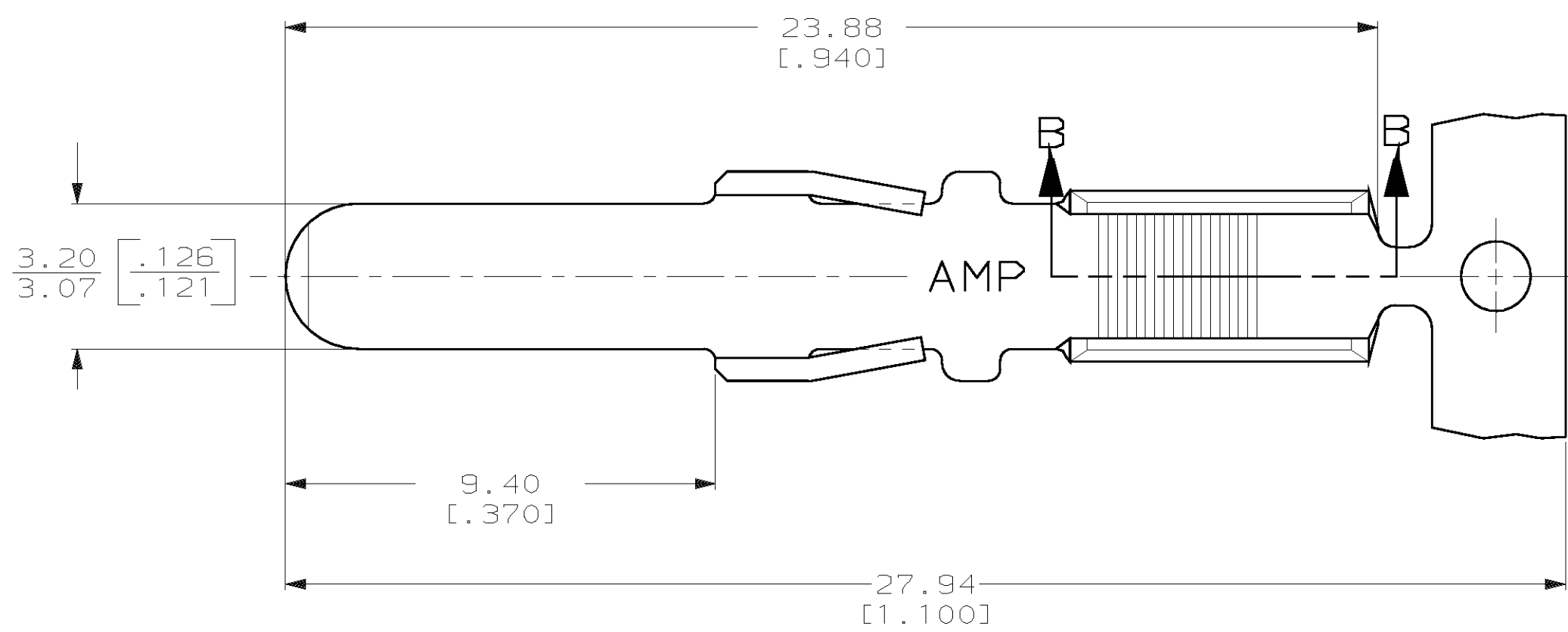

1 CONTINUOUS STRIP ON REEL.

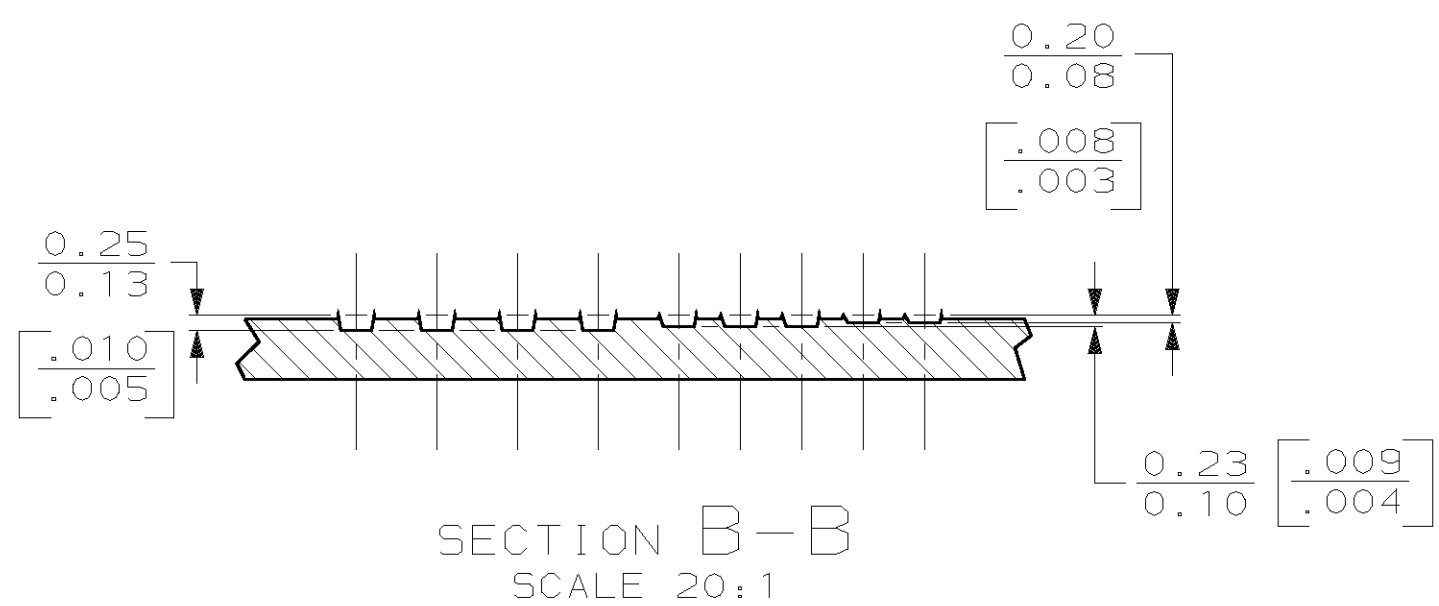
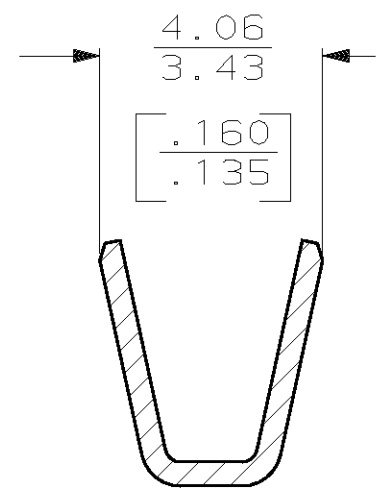
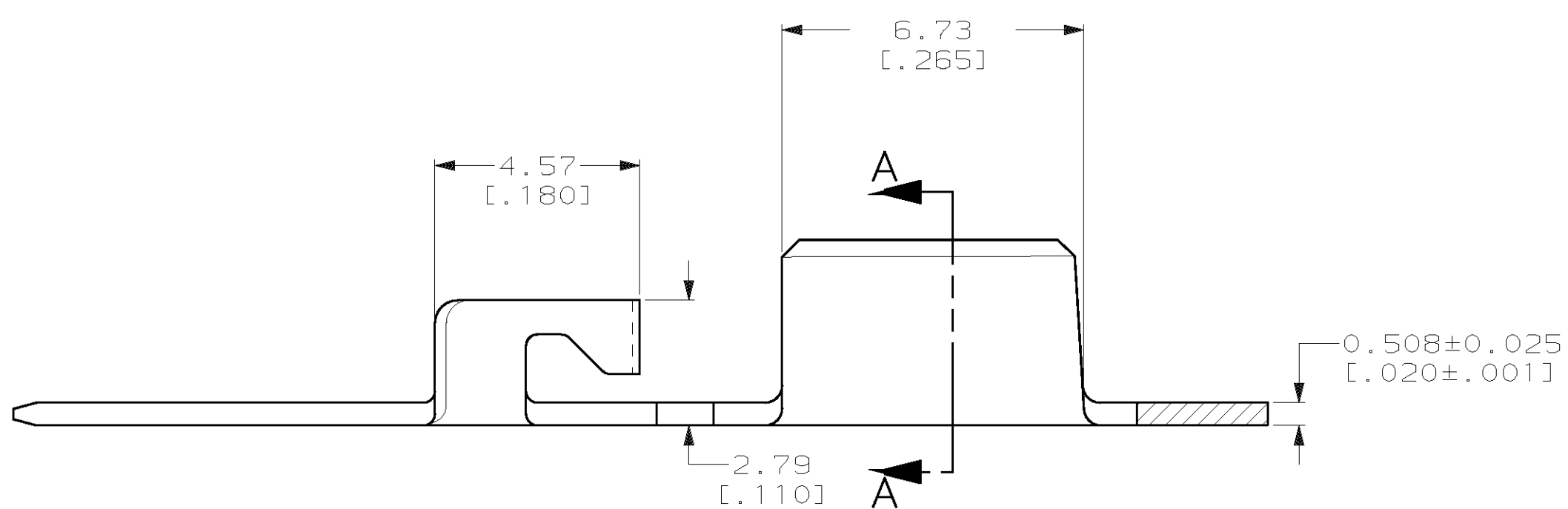
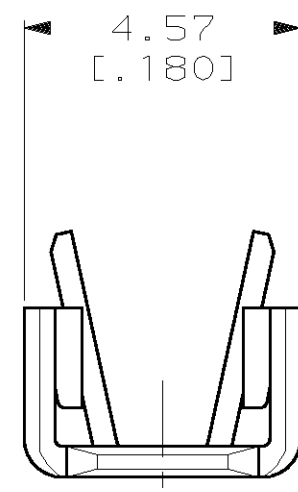

SECTION B-B
SCALE 20:1

1500-5000 CMA	1217073-1
WIRE RANGE	PART NO

DO NOT SCALE PRINT. UNLESS SPECIFIED DIMENSIONS IN mm [INCHES] TOLERANCES ON: 2 PLC DEC ± 0.25 [.010] 3 PLC DEC ± - ANGLES ± -	DR 3/10/98 JR RUTH	AMP Incorporated Harrisburg, PA 17105-3608		
	CHK 3/10/98 P FORTNEY			NAME
MATERIAL 4M BRASS	APPD 3/10/98 DON DECKER	CONTACT, 3.18 [.125] BLADE, AMPLIVAR		
FINISH 0.002032 [.000080] MIN TIN PL PER MIL-T-10727	APPD 3/10/98 D BRATINA			
	PRODUCT SPEC -	SIZE	CAGE CODE	DRAWING NO
	APPLICATION SPEC -	③	00779	③=1217073
	WEIGHT -	SCALE	8:1	SHEET 1 OF 1

THIS DRAWING IS A CONTROLLED DOCUMENT FOR AMP INCORPORATED. IT IS SUBJECT TO CHANGE AND THE CONTROLLING ENGINEERING ORGANIZATION SHOULD BE CONTACTED FOR THE LATEST REVISION.