



金龙机电股份有限公司

JINLONG MACHINERY & ELECTRONICS



www.jinlong-machinery.com

sales@jinlong-machinery.com

规格书

SPECIFICATION

客户信息	客户名称/Customer	
	客户料号/Part No.	
	客户承认签章 Customer Approved Signatures	

文件编号/Spec No.		
品名/Description	圆柱直流马达/Cylindrical DC motor	
型号/Part No.	Z30C1B839981A	
设计/Designed	审核/Checked	批准/Approved
		
2015.05.25	2017.05.25	2017.05.25



MATERIAL or METHODS Specification

no. Z3OC1B839981A

TITLE: **Motor, Vibrator, 3.0 Volts, 12000 RPM, 12.5x6.50x3.35mm Flat, SMD**

DATE: **Dec-20- 16**

MEMO: **SN0408000**

ISSUE: **02**

PAGE: **1 of 15**

Date	Originator	Version	Description of changes				
Dec.20.16	S.Liang	01	Initial	Spec	Release		
May.25.17	S.Liang	02	Colanarity with respect to A as standard B&C&D tolerance changed				
Jinlong Machinery & Electronics Co.,Ltd Jinlong Technology Zone,Jingang Road, Baixiang Yueqing Zhejiang China			Approval	Exam	Check	Design	
			SUI P.CH 2017.05.25				

**MATERIAL or METHODS Specification**

NO. Z3OC1B839981A

TITLE: **Motor, Vibrator, 3.0 Volts, 12000 RPM, 12.5x6.50x3.35mm Flat, SMD**DATE: **Dec-20- 16**MEMO: **SN0408000**ISSUE: **02**PAGE: **2 of 15**

Preface:

Thank you very much for your selecting the KOTL Z3OC1B839981A vibrator. Our products have stable performance. To obtain maximum performance from the product, please read this specification first, and keep it handy for future reference.



TITLE: **Motor, Vibrator, 3.0 Volts, 12000 RPM, 12.5x6.50x3.35mm Flat, SMD**

DATE: **Dec-20- 16**

MEMO: **SN0408000**

ISSUE: **02**

PAGE: **3 of 15**

TABLE OF CONTENTS

SECTION	DESCRIPTION	PAGE#
1.SCOPE.....		4
2. MECHANICAL CHARACTERISTIC.....		4
3. ELECTRICAL CHARACTERISTICS.....		4
4. ADDITIONAL INFORMATION.....		5
5. CRITICAL CHARACTERISTICS.....		5
6. ENVIRONMENTAL CHARACTERISTICS.....		5
7. RELIABILITY TESTS.....		5
8. VIBRA DRIVER REQUIREMENTS FOR OPERATIONAL TESTS.....		8
9. QUALITY ASSURANCE.....		8
10. MATERIALS.....		8
11. LOT NO. INDICATION ON THE VIBRATOR.....		9
12. PACKAGING CONDITION		9
13. RECOMMENDED REFLOW PROFILE FOR VIBRATOR.....		12
14. NOTES ON USE.....		13
APPENDIX 1		15
APPENDIX 2		16

1. SCOPE

TITLE: Motor, Vibrator, 3.0 Volts, 12000 RPM, 12.5x6.50x3.35mm Flat, SMD

 DATE: **Dec-20- 16**

 MEMO: **SN0408000**

 ISSUE: **02**

 PAGE: **4 of 15**

This document contains specific electrical and mechanical characters, critical characteristics, reliability tests, packaging condition, quality assurance, reflow profile and etc..

2. MECHANICAL CHARACTERISTIC

- | | |
|---|-----------------------|
| 2.1. Mechanical drawing | See appendix 2 |
| 2.2. Axial play of shaft | 0.3 mm Max |
| 2.3. Counter weight density: | 17.0 g / cc Min |
| 2.4. Mechanical noise of motor operating at rated speed: | 45 dB Max A-weighting |
| Background noise 26dB.(Measured distance 10 cm, see appendix 1 Figure 1.1). | |

3. ELECTRICAL CHARACTERISTICS

- | | |
|--|---------------------------------------|
| 3.1. Vibrator positioning: | Horizontal |
| 3.2. Operating voltage: | 3.0 V |
| 3.3. Operating voltage range: | 2.3– 3.6V |
| 3.4. Load current at operating voltage: | 85 mA Max |
| 3.5. Starting current at operating voltage: | 100 mA Max |
| 3.6. Insulation resistance and voltage break down: | at 100V DC, 1M Ω Min and above |
| 3.7. Terminal resistance: | 30.0 \pm 5.0 Ω |
| 3.8. Load speed: | 12000 \pm 2500 rpm |
| 3.9. Rotation direction: | C.W. & C.C.W |
| 3.10. Motor vibration Force: | 0.20 G Min |
| (The G-force is 0.20G min when the motor is under the loading of 100g at rated voltage, see appendix 1 Figure 1.2) | |
| 3.11. Rise time (see picture 1) | 100 ms Max |
| 3.12. Rree Fall time (see picture 1) | 70 ms Max |
| -From zero to 90% of nominal speed | |
| -From nominal velocity to 10% of nominal speed | |

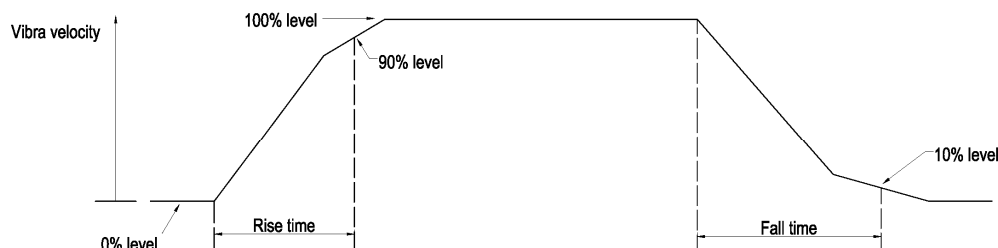

Picture 1 RPM rise and fall time

- 3.13 Standard loaded starting voltage: Under standard loaded condition, towards C.W. rotor shall

TITLE: **Motor, Vibrator, 3.0 Volts, 12000 RPM, 12.5x6.50x3.35mm Flat, SMD**DATE: **Dec-20- 16**MEMO: **SN0408000**ISSUE: **02**PAGE: **5 of 15**

move in all position at 2.3V (counterweight should be turned slowly at 360°)

All mechanical and electrical measurements should be measured at room temperature and ordinary humidity.

4. ADDITIONAL INFORMATION

- 4.1. Vibrator weight 0.75g
- 4.2. Pull out strength of counter weight and shaft 30N Min
- 4.3. Acceleration level at nominal RPM (Grms) (test jig mounted in freely suspended)
- 4.4. Speed and current variation (function of temperature, -20°C to +70°C)

5. CRITICAL CHARACTERISTICS

- 5.1. Functional dimensions
- 5.2. Rated current at specified rotating speed
- 5.3. Operating speed at operating voltage
- 5.4. Starting current at operating voltage
- 5.5. Min. starting Voltage

6. ENVIRONMENTAL CHARACTERISTICS

- 6.1. Operating temperature ranges: -20°C to +70°C
- 6.2. Storage temperature ranges: -40°C to +85°C

7. RELIABILITY TESTS

7.1 We have already performed reliability tests and measure nom rotation speed, nom load current, nom resistance, nom starting currents and nom starting voltage before and after tests, please check following table1 for detail reliability test information. Each test we use at least 10 samples for verification.

	Items	Test conditions	Judgment
7.2	Low temperature storage test	Storage test -40±3°C/96h, recovery 1~2h Measurements with test jig.	No mechanical damage. Normal performance of vibrator. (Max +/-30% variation of nom RPM)

TITLE: Motor, Vibrator, 3.0 Volts, 12000 RPM, 12.5x6.50x3.35mm Flat, SMD

 DATE: **Dec-20- 16**

 MEMO: **SN0408000**

 ISSUE: **02**

 PAGE: **6 of 15**

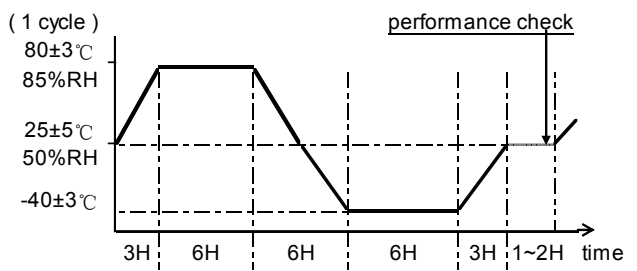
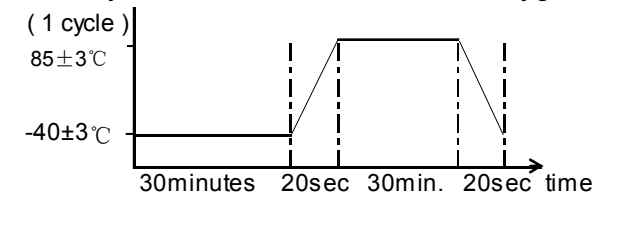
7.3	High temperature storage test	Storage test $80\pm 3^{\circ}\text{C}/96\text{h}$, recovery 1~2h Measurements with test jig.	No mechanical damage. Normal performance of vibrator. (Max +/-30% variation of nom RPM)
7.4	Temperature cyclic test	Storage test Temperature & humidity: $+80\pm 3^{\circ}\text{C}/6\text{h}(\text{RH}85\%)$; $-40\pm 3^{\circ}\text{C}/6\text{h}$ with 6h maximum transition time between temperatures. 24h/cycles, totally 6 cycles. Recovery 1~2h. Performance check daily. Measurements with test jig.  <p>(1 cycle)</p> <p>80±3°C 85%RH 25±5°C 50%RH -40±3°C</p> <p>3H 6H 6H 6H 3H 1~2H time</p> <p>performance check</p>	No mechanical damage. Reduced performance of vibrator. (Max +/-30% variation of nom RPM)
7.5	Thermal shock test	Storage test Temperature & humidity: $-40\pm 3^{\circ}\text{C}/30\text{minutes}$; $+85\pm 3^{\circ}\text{C}/30\text{minutes}$ with a 20sec maximum transition time between temperatures. 1h/cycle, totally 50 cycles. Recovery 1~2h. Measurements with test jig.  <p>(1 cycle)</p> <p>85±3°C -40±3°C</p> <p>30minutes 20sec 30min. 20sec time</p>	No mechanical damage. Normal performance of vibrator. (Max +/-30% variation of nom RPM)
7.6	Room temperature lifetime test	Operational test: apply operating voltage Temperature & humidity: $25\pm 3^{\circ}\text{C}$, RH 50% On/off time: 2.5s on/off, 300,000 cycles. Performance check: before, after test and every 20,000 cycles. Recovery 1-2h. Measurements with test jig.	No mechanical damage. <u>After 100,000cycles:</u> Normal performance of vibrator. (Max +/-30% variation of nom RPM) <u>After 300,000cycles:</u> The vibrator should operate.

TITLE: Motor, Vibrator, 3.0 Volts, 12000 RPM, 12.5x6.50x3.35mm Flat, SMD

 DATE: **Dec-20- 16**

 MEMO: **SN0408000**

 ISSUE: **02**

 PAGE: **7 of 15**

7.7	High temperature lifetime test	Operational test: apply operating voltage Temperature : 55±3°C On/off time: 2.5s on/off, 53,000 cycles. Performance check: before, after test and every 20,000 cycles. Recovery 1~2h. Measurements with test jig.	No mechanical damage. Normal performance of vibrator. (Max +/-30% variation of nom RPM)												
7.8	Low temperature lifetime test	Operational test: apply operating voltage Temperature : -20±3°C On/off time:2.5s on/off, 53,000 cycles. Performance check: before, after test and every 20,000 cycles. Recovery 1~2h. Measurements with test jig.	No mechanical damage. Normal performance of vibrator. (Max +/-30% variation of nom RPM)												
7.9	H ₂ S corrosion test	Storage test Concentration: 3±1ppm Temperature & humidity: 40±3°C, RH 80% Exposure time: 24hours	No mechanical damage. Normal performance of vibrator. (Max +/-30% variation of nom RPM)												
7.10	Free Fall	Mount the vibrator in the dummy box.(dummy box weight 100g), Drop height 1.5 m onto concrete. 3 times in each 6 directions. Measurements with test jig.	No mechanical damage. Normal performance of vibrator. (Max +/-30% variation of nom RPM)												
7.11	Random vibration test	<table border="1"> <tr> <td colspan="2">3axes, 10minutes per axis, 6.06Grms</td> </tr> <tr> <td>Frequency (Hz)</td> <td>A.S.D.(G²/Hz)</td> </tr> <tr> <td>20</td> <td>0.0098</td> </tr> <tr> <td>80</td> <td>0.04</td> </tr> <tr> <td>350</td> <td>0.04</td> </tr> <tr> <td>2000</td> <td>0.0069</td> </tr> </table> Measurements with test jig.	3axes, 10minutes per axis, 6.06Grms		Frequency (Hz)	A.S.D.(G ² /Hz)	20	0.0098	80	0.04	350	0.04	2000	0.0069	No mechanical damage. Normal performance of vibrator. (Max +/-30% variation of nom RPM)
3axes, 10minutes per axis, 6.06Grms															
Frequency (Hz)	A.S.D.(G ² /Hz)														
20	0.0098														
80	0.04														
350	0.04														
2000	0.0069														
7.12	Shock test	Time of test and direction: 3times in each 6 direction. Total 18 times. Acceleration: Half-sinusoidal 500G Duration:2ms	No mechanical damage. Normal performance of vibrator. (Max +/-30% variation of nom RPM)												

Table1 Reliability test

TITLE: **Motor, Vibrator, 3.0 Volts, 12000 RPM, 12.5x6.50x3.35mm Flat, SMD**DATE: **Dec-20- 16**MEMO: **SN0408000**ISSUE: **02**PAGE: **8 of 15****8. EXPECTED SHIPPING AND STORAGE CONDITIONS**

- | | |
|------------------------------------|------------------------|
| 8.1. Relative humidity | 15%~70% |
| 8.2. Temperature | -5°C~40°C |
| 8.3. Sulphur dioxide average | 0.3 mg/m ³ |
| 8.4. Sulphuretted hydrogen average | 0.1 mg/ m ³ |
| 8.5. Storage period | 12 months |

(Vibrator has to be rotated at least once within 12 months from the date of receipt)

9. QUALITY ASSURANCE

All critical parameters are 100% in control. The symbols “◆” apply to all parameters identified as critical parameters in all process. And before mass production approval, we use Process Capability Study (PCS) to conduct all critical parameters in mass production. Based on PCS the final quality controls will be agreed.

Quality assurance for mass production:

- Lot acceptance rate (LAR)
- First pass yield (FPY)
- Outgoing quality level

Each final packing containing Out-going inspection data sheet (n=35pcs)

Inspection item: Load speed
Load current
Starting current
Starting voltage
Coil resistance

- Customer reject material rate
- Customer satisfaction
- Cpk/Cp control for all critical parameters (except starting voltage)

10. MATERIALS

- Counterweight
- Brush
- Commutator
- Case
- Terminal
- Bracket
- Washer
- End cover
- Bearing
- Magnet
- Copper wire
- Shaft
- Core
- Varistor

TITLE: Motor, Vibrator, 3.0 Volts, 12000 RPM, 12.5x6.50x3.35mm Flat, SMD

 DATE: **Dec-20- 16**

 MEMO: **SN0408000**

 ISSUE: **02**

 PAGE: **9 of 15**

P.S.: All the materials included in vibrator can meet 2002/95/EC & KOTL RoHS requirement KOTL-III-TD-001.

11. LOT NO. INDICATION ON THE VIBRATOR

Following markings are the definition of lot no. indication on the vibrator, which including production code and date code; please see picture 2 as below for detail information:

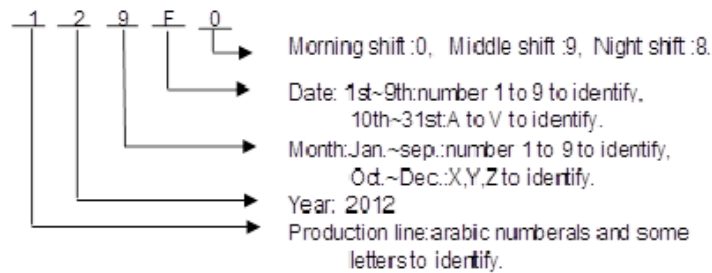

Date	1	2	3	4	5	6	7	8	9	10	11	12	13	14	15	16	17	18	19	20
Lot No. Insication	1	2	3	4	5	6	7	8	9	A	B	C	D	E	F	G	H	I	J	K
Date	21	22	23	24	25	26	27	28	29	30	31									
Lot No. Insication	L	M	N	O	P	Q	R	S	T	U	V									
Date	V1	V2	V3	V4	V5	V6	V7	V8	V9	V10	V11	V12	V13	V14	V15	V16	V17	V18	V19	V20
Production line code	1	2	3	4	5	6	7	8	9	A	B	C	D	E	F	G	H	I	J	K

Picture 2 Lot No. indication

12. PACKAGING CONDITION

A detailed mechanical drawing for packing condition as followed with dimensions and tolerances:

13.1 Smallest packing

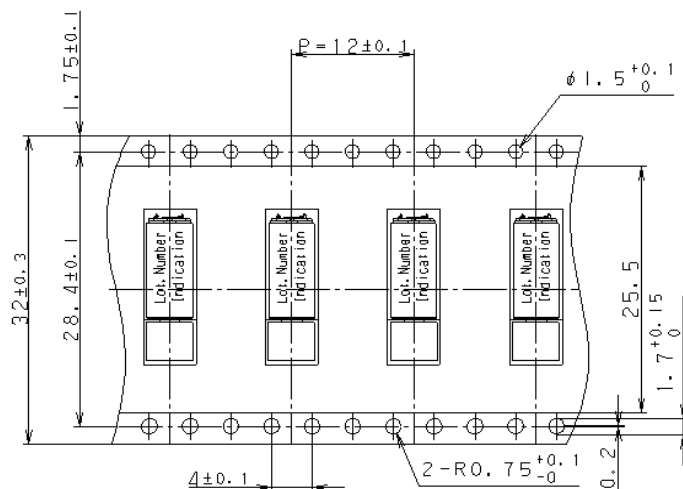

TITLE: **Motor, Vibrator, 3.0 Volts, 12000 RPM, 12.5x6.50x3.35mm Flat, SMD**DATE: **Dec-20- 16**MEMO: **SN0408000**ISSUE: **02**PAGE: **10 of 15**

Picture 3 Smallest packing condition

12.2 Reel packing condition

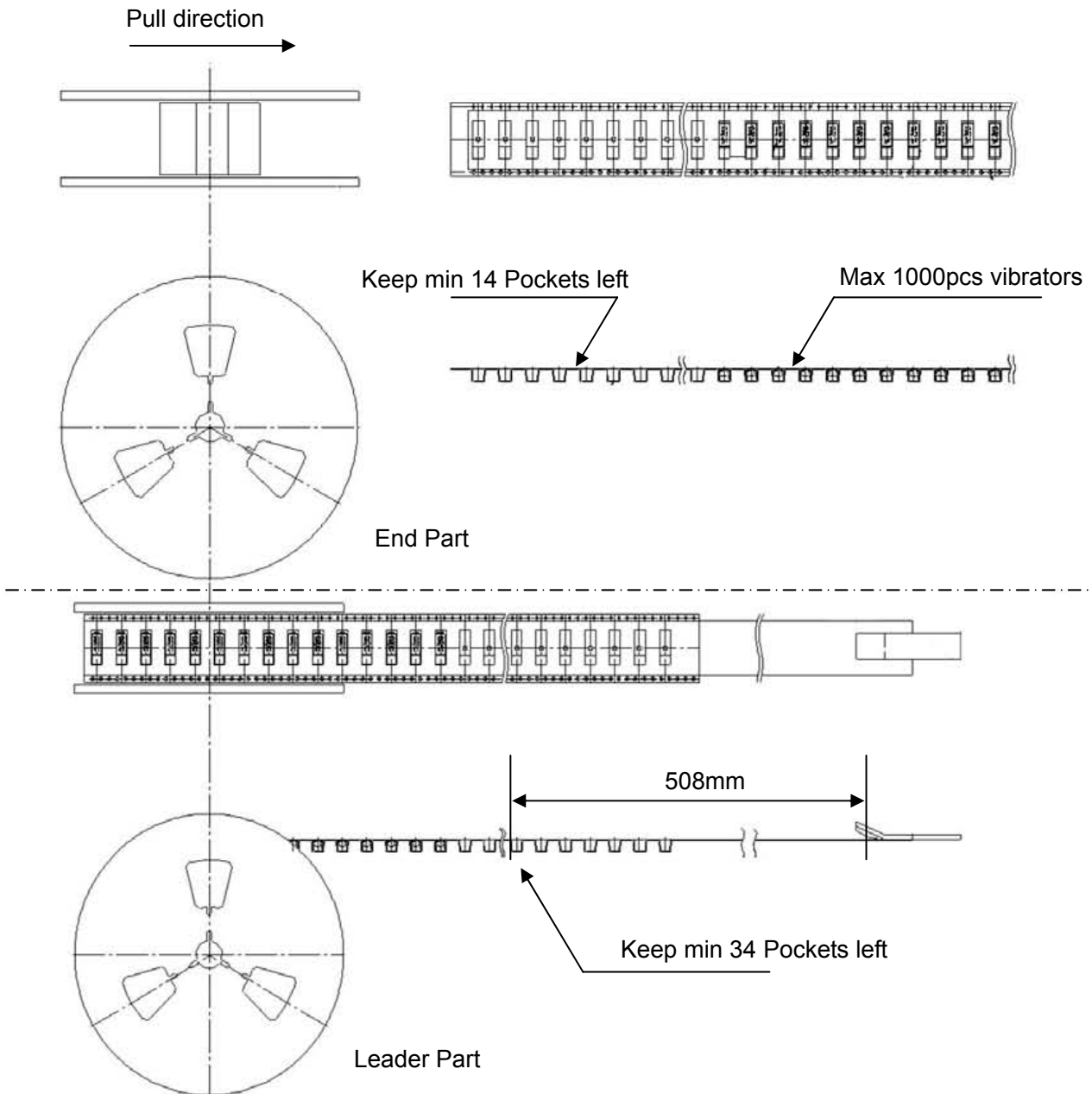

Picture 4 Reel packing condition

TITLE: **Motor, Vibrator, 3.0 Volts, 12000 RPM, 12.5x6.50x3.35mm Flat, SMD**DATE: **Dec-20- 16**MEMO: **SN0408000**ISSUE: **02**PAGE: **11 of 15**

12.3 Final packing condition

1000pcs/reel X 6reel= total 6000pcs

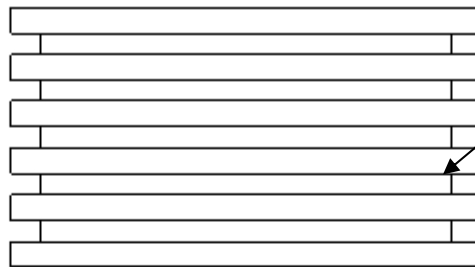

During the vibrator handle or shipping, counterweight must be faced to upper side.

Double wall corrugated cardboard

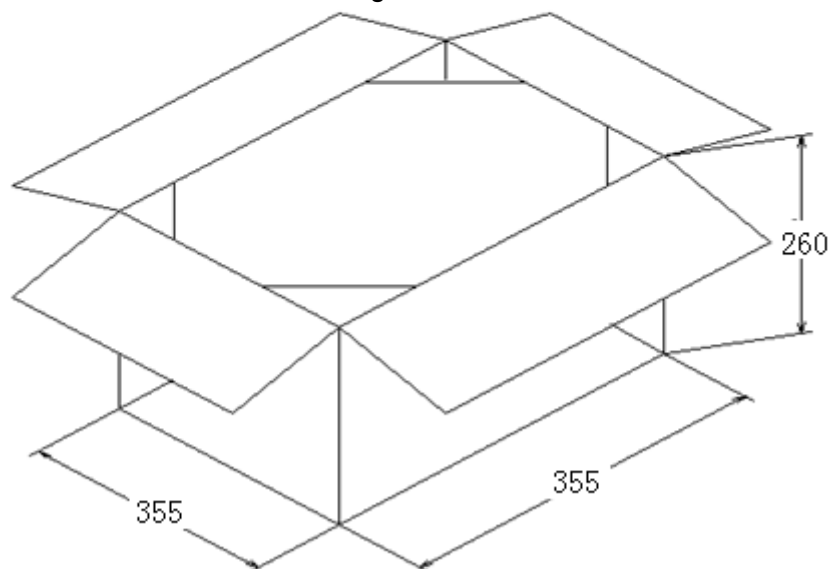

Picture 5 Final packing condition

12.4 Accessories included in final package

Out-going inspection data sheet (n=35pcs) will be attached for each lot, we do implemented inspection after reflow. Inspection item including:

- Load speed
- Load current
- Starting current
- Starting voltage
- Coil resistance

TITLE: Motor, Vibrator, 3.0 Volts, 12000 RPM, 12.5x6.50x3.35mm Flat, SMD

 DATE: **Dec-20- 16**

 MEMO: **SN0408000**

 ISSUE: **02**

 PAGE: **12 of 15**

13. RECOMMENDED REFLOW PROFILE FOR VIBRATOR

13.1 Definitions

Reflow Profile = Time vs. temperature plot

Peak temperature = Maximum temperature reached on the component

Convection = Forced air heating

13.2 Recommended temperature check method of reflow furnace

The reflow furnace used should be 100% convection reflow. Thermocouples should be securely attached to the top surface of vibrator to insure the temperature exposure is met. Profile should be recorded by data acquisition for future reference.

13.3 Recommended reflow Profile for Pb-Free soldering

Temperature(°C)

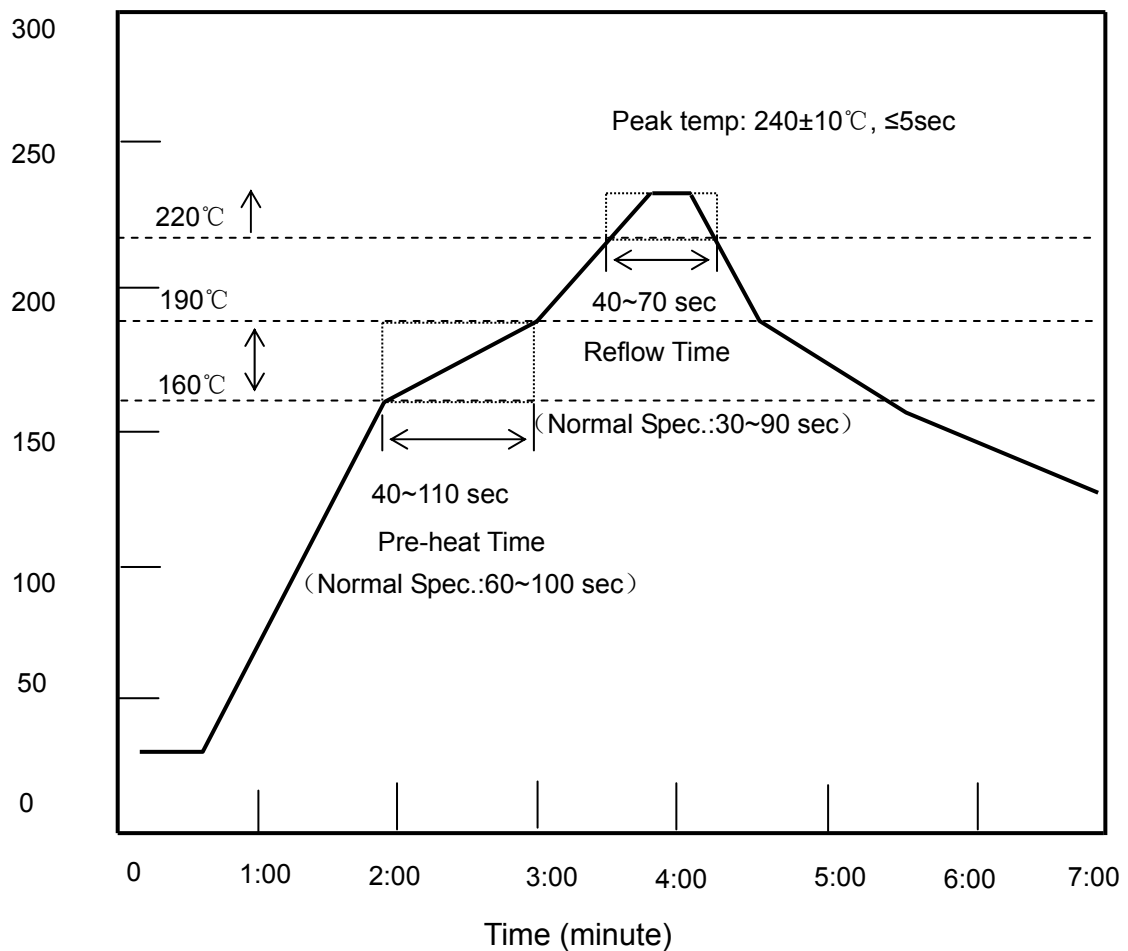



TITLE: **Motor, Vibrator, 3.0 Volts, 12000 RPM, 12.5x6.50x3.35mm Flat, SMD**

DATE: **Dec-20- 16**

MEMO: **SN0408000**

ISSUE: **02**

PAGE: **13 of 15**

14. NOTES ON USE

- 14.1 Pay attention to the voltage and current ranges which applied to the vibrator, and use the vibrator in accordance with this specification, otherwise, it will reduce the life and performance of the vibrator.
- 14.2 Do not use hot gun to puff the surface of vibrator from PCB directly.
- 14.3 Do not locking the motor with current applied for long time, which may cause the motor to overheat and short circuit.
- 14.4 Do not exert pressure the terminals, otherwise, it will result in terminal deformation.
- 14.5 Do not bring magnetized objects near or contact with the surface of vibrator, which will demagnetize the magnetism of vibrator and result in noise failure.

Appendix 1

Figure 1.1: Mechanical noise measurements setup

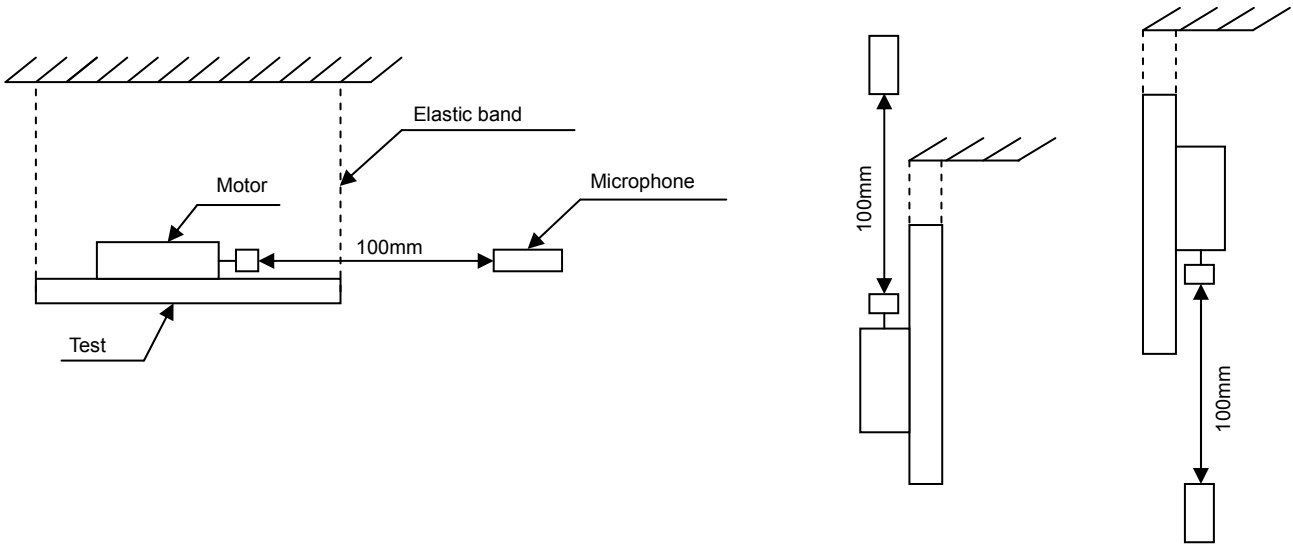
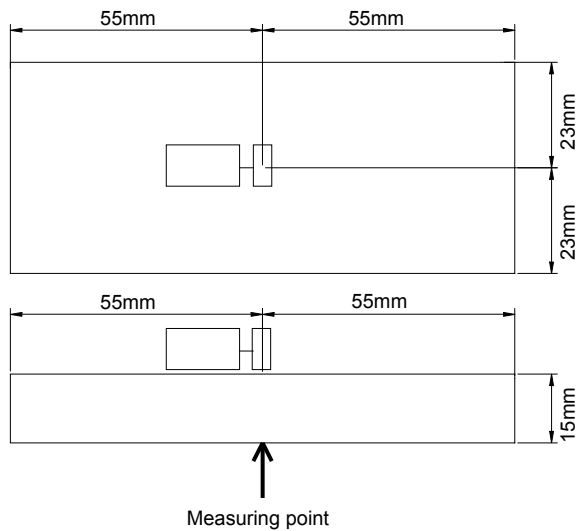

Figure1.2:Test jig, weight 100g



5		6	
No.	Change Record	Name	Date
01	Initial release	梁帅	2016.12.11

A

A

B

B

C

C

D

D

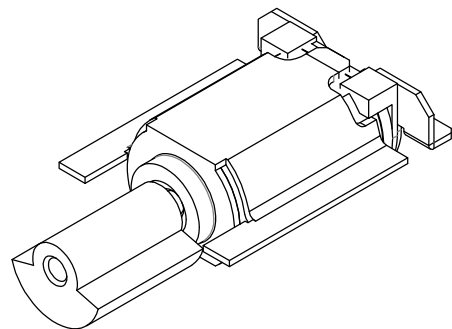

CW

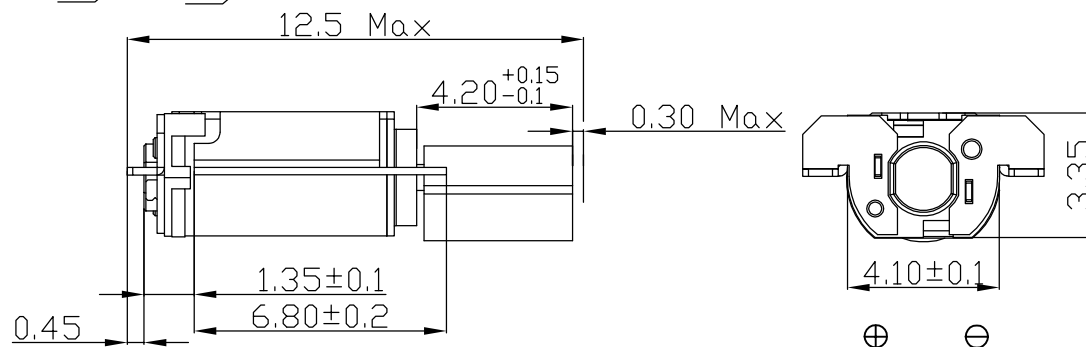
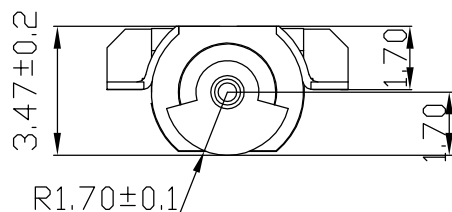
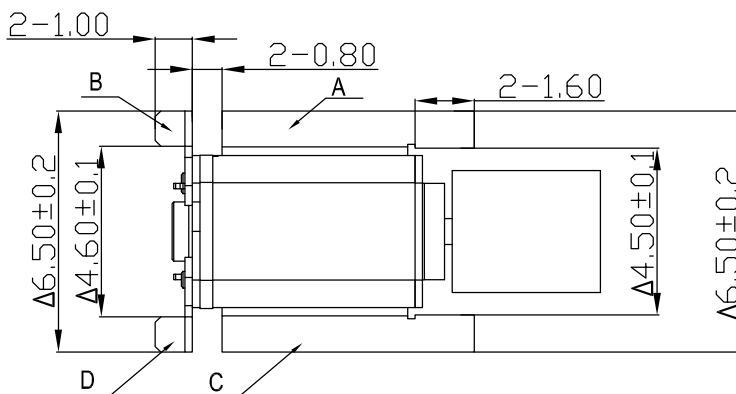

NOTES:

Δ1.Coplanarity with respect to A as standard ,B &C&D tolerance is -0.05mm~+ 0.08mm

PCB Patten and Cut

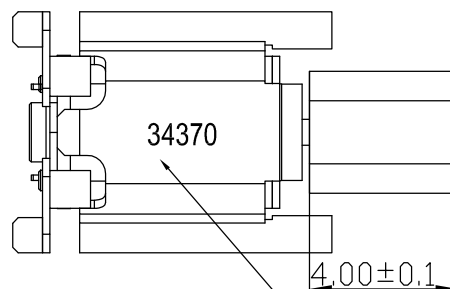
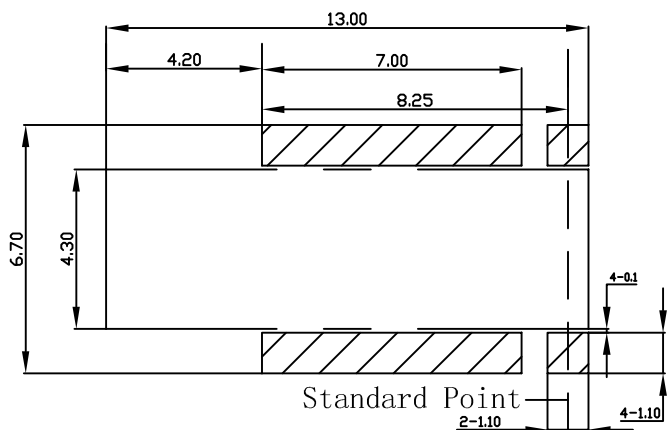

Lot. Number Indication

 Jin Long Machinery & Electronics jinlong-machinery.com	
Serial	Motor Name
FC	Z30C1B839981A

Rev.	Material	Unit	Treatment	Part Name
01		mm		马达外观 Motor Figure
1st Angle	Tolerance	Scale	Size	
	±0.05 ±1°	10/1	A4	Part Number
Desing	Exam.	Check	Approval	Z30C1B839981A
梁帅	/	/	陈随鹏	